

# TS0759

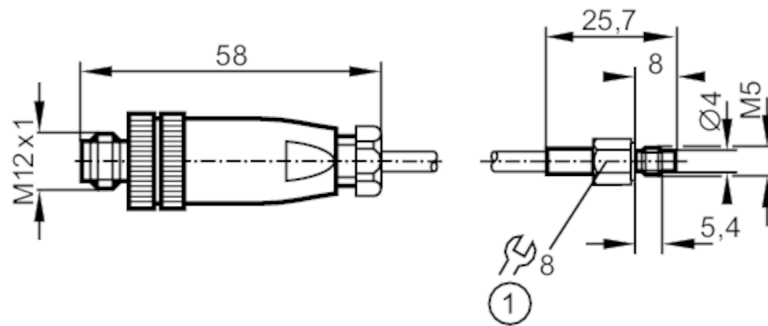

## Temperature cable sensor with screw-in sensor

TS-PT100-SCREW-IN M5



1 Tightening torque 1.5 Nm



Product characteristics		
Measuring range	-30...180 °C	-22...356 °F
Process connection	threaded connection M5 external thread	
Application		
Measuring element	1 x Pt 100; (to DIN EN 60751, class A)	
Installation	surface mount RTD for solid bodies	
Electrical data		
Protection class	III	
Measuring/setting range		
Measuring range	-30...180 °C	-22...356 °F
Accuracy / deviations		
Accuracy	[K]	± (0,15 K + 0,002 x t )
Response times		
Dynamic response T05 / T09	[s]	3 / 8; (to DIN EN 60751)
Operating conditions		
Protection	IP 67	
Tests / approvals		
MTTF	[years]	10377.8
Mechanical data		
Weight	[g]	394.25
Housing	cylindrical	
Design	screw-in sensor	
Materials	stainless steel (316L/1.4404)	
Process connection	threaded connection M5 external thread	
Remarks		
Pack quantity	1 pcs.	

# TS0759



## Temperature cable sensor with screw-in sensor

TS-PT100-SCREW-IN M5

### Electrical connection

Cable: 10 m, silicone

Connector: 1 x M12; coding: A



### Connection

