

# IG6055

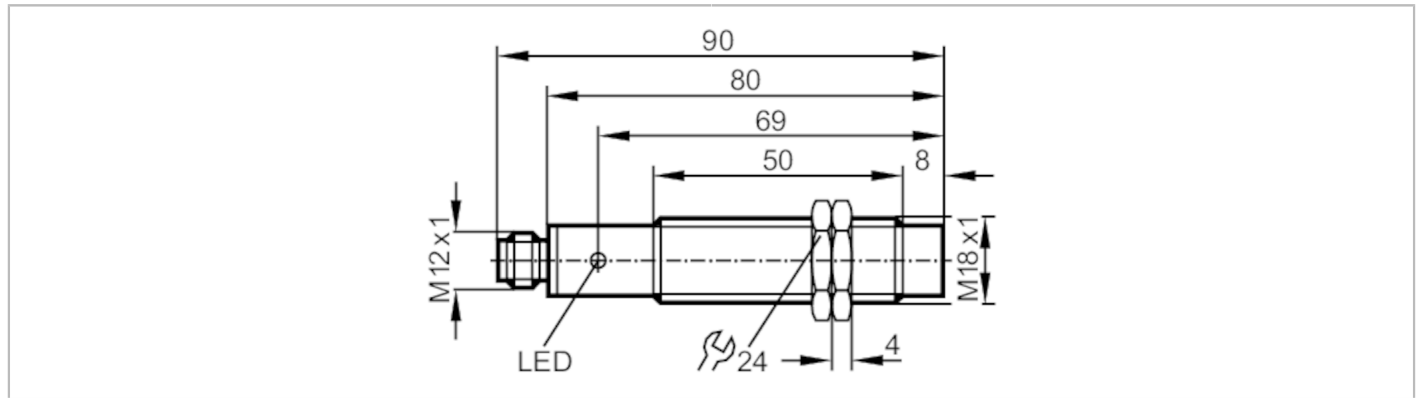

## Inductive sensor

IGA3008-BPKG/V4A/US-100-DPS



Product characteristics	
Electrical design	PNP
Output function	normally open
Sensing range [mm]	8
Housing	threaded type
Dimensions [mm]	M18 x 1 / L = 90
Application	
Special feature	Gold-plated contacts
Electrical data	
Operating voltage [V]	10...36 DC
Current consumption [mA]	15; (24 V)
Protection class	II
Reverse polarity protection	yes
Outputs	
Electrical design	PNP
Output function	normally open
Max. voltage drop switching output DC [V]	2.5
Permanent current rating of switching output DC [mA]	250
Short-time current rating of switching output [mA]	250
Switching frequency DC [Hz]	300
Short-circuit protection	yes
Type of short-circuit protection	pulsed
Overload protection	yes
Detection zone	
Sensing range [mm]	8
Real sensing range $S_r$ [mm]	$8 \pm 10 \%$
Operating distance [mm]	0...6.48
Accuracy / deviations	
Correction factor	steel: 1 / stainless steel: 0.7 / brass: 0.4 / aluminium: 0.3 / copper: 0.2

# IG6055



## Inductive sensor

IGA3008-BPKG/V4A/US-100-DPS

Hysteresis	[% of Sr]	1...15
Switch point drift	[% of Sr]	-10...10

### Operating conditions

Ambient temperature	[°C]	-25...80
Protection		IP 67

### Tests / approvals

EMC	EN 60947-5-2	
	EN 55011	class B
MTTF	[years]	1853

### Mechanical data

Weight	[g]	65.2
Housing		threaded type
Mounting		non-flush mountable
Dimensions	[mm]	M18 x 1 / L = 90
Thread designation		M18 x 1
Materials		stainless steel (1.4571/316Ti ); sensing face: PC

### Displays / operating elements

Display	switching status	1 x LED, yellow
---------	------------------	-----------------

### Accessories

Items supplied		lock nuts: 2
----------------	--	--------------

### Remarks

Pack quantity		1 pcs.
---------------	--	--------

### Electrical connection - plug

Connector: 1 x M12; coding: A; Contacts: gold-plated



### Connection

