

IGM213

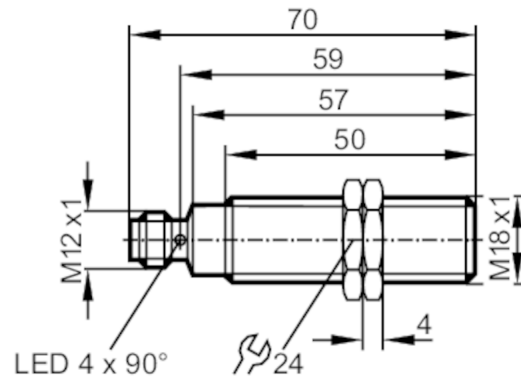

Inductive sensor

IGKC008BATKG/M/US



Product characteristics

Electrical design		NPN
Output function		normally open
Sensing range	[mm]	8
Housing		threaded type
Dimensions	[mm]	M18 x 1 / L = 70

Application

Special feature		Gold-plated contacts; Increased sensing range
Application		Use in mobile and harsh applications

Electrical data

Operating voltage	[V]	10...36 DC
Current consumption	[mA]	< 10
Protection class		II
Reverse polarity protection		yes

Outputs

Electrical design		NPN
Output function		normally open
Max. voltage drop switching output DC	[V]	2.5
Max. leakage current	[mA]	0.5
Permanent current rating of switching output DC	[mA]	100
Switching frequency DC	[Hz]	200
Short-circuit protection		yes
Type of short-circuit protection		pulsed
Overload protection		yes

Detection zone

Sensing range	[mm]	8
Operating distance	[mm]	0...6.48

IGM213



Inductive sensor

IGKC008BATKG/M/US

Increased sensing range		yes
Accuracy / deviations		
Correction factor		steel: 1 / stainless steel: 0.7 / brass: 0.5 / aluminium: 0.45 / copper: 0.35
Hysteresis	[% of Sr]	1...20
Operating conditions		
Ambient temperature	[°C]	-40...85
Protection		IP 67; IP 69K
Tests / approvals		
EMC	automotive area	
	noise emission and noise interference: ECE R10	E1 type approval
	noise immunity according to DIN ISO 11452-2	100 V/m
	conducted interference in 24 V networks to ISO 7637-2: 2004 (pulse 1 to 4) and ISO16750-2: 2012 (load dump)	
	pulse	1 2a 2b 3a 3b 4 Load dump
	severity level	III III III III III Test A
	failure criterion	C A C A A C C
	EN 61000-4-2 ESD	4 kV CD / 8 kV AD
	EN 61000-4-3 HF radiated	10 V/m
	EN 61000-4-4 Burst	2 kV
	EN 61000-4-5 Surge	0,5 kV mains line to line
	EN 61000-4-6 HF conducted	10 V
	EN 55011	class B
	Vibration resistance	EN 60068-2-6 Fc
EN 60068-2-27 Ea		100 g 11 ms half-sine; 3 shocks each in every direction of the 3 coordinate axes / -40...85 °C
Shock resistance	EN 60068-2-27	40 g 6 ms; 4000 shocks each in every direction of the 3 coordinate axes / -20...50 °C
Continuous shock resistance	EN 60068-2-14 Na	TA = -40 °C; TB = 85 °C; t1 = 30 min; t2 = < 10 s; 50 cycles
Fast temperature change	EN 60068-2-52 Kb	severity level 5 (4 test cycles)
Salt spray test	MTTF	[years] 1192
UL approval	Ta	-40...85 °C
	Enclosure type	Type 1
	power supply	Limited Voltage/Current
	File number UL	E174191
Mechanical data		
Weight	[g]	53.5
Housing		threaded type
Mounting		flush mountable
Dimensions	[mm]	M18 x 1 / L = 70
Thread designation		M18 x 1
Materials		housing: stainless steel (1.4404 / 316L); sensing face: LCP

IGM213



Inductive sensor

IGKC008BATKG/M/US

Displays / operating elements		
Display	switching status	4 x 90° LED, yellow
Accessories		
Items supplied		lock nuts: 2
Remarks		
Pack quantity		1 pcs.

Electrical connection - plug

Connector: 1 x M12; coding: A; Contacts: gold-plated

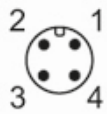

Connection

