

E11030

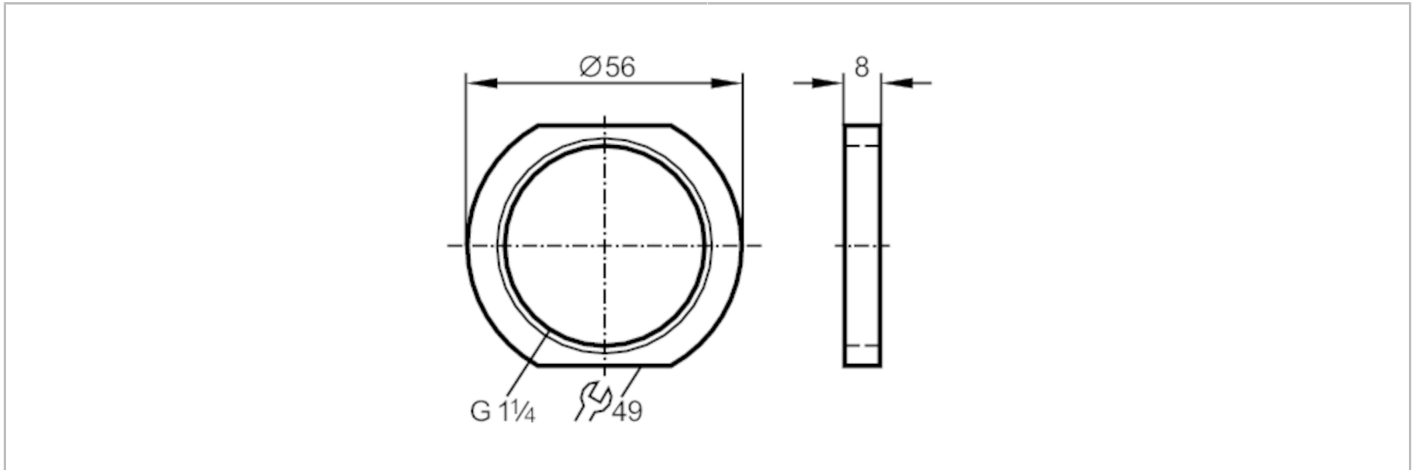

Lock nut for mounting adapter

NUT MOUNTING ADAPTER PVDF



Application

Design for mounting adapters

Operating conditions

Ambient temperature [°C] -25...110

Mechanical data

Weight [g]	15.8
Dimensions [mm]	G 1¼
Thread designation	G 1¼
External diameter [mm]	56
Materials	PVDF

Remarks

Pack quantity 1 pcs.