

O8S200

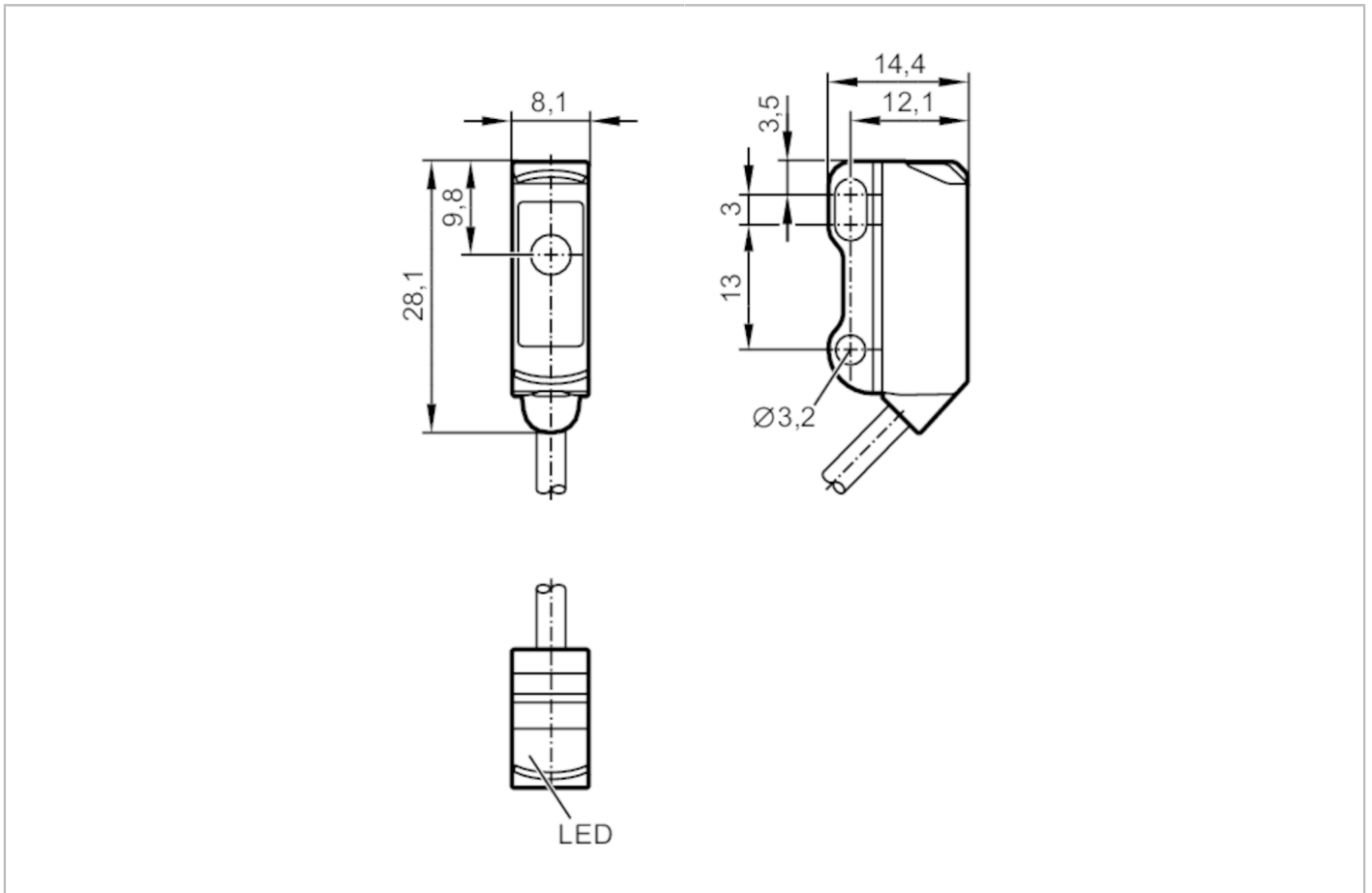

Through-beam sensor transmitter

O8S-00KG/2,0M



Application	
Function principle	Through-beam sensor
Electrical data	
Operating voltage [V]	10...30 DC
Current consumption [mA]	12; ((24 V))
Protection class	III
Reverse polarity protection	yes
Type of light	red light
Wave length [nm]	633
Range	
Transmitter / receiver	transmitter
Range [m]	< 3
Max. light spot diameter [mm]	200
Light spot dimensions refer to	at maximum range
Operating conditions	
Ambient temperature [°C]	-25...60
Protection	IP 65; IP 67
Tests / approvals	
EMC	EN 60947-5-2

O8S200



Through-beam sensor transmitter

O8S-OOKG/2,0M

Mechanical data

Weight	[g]	39.6
Housing		rectangular
Dimensions	[mm]	28.1 x 8.1 x 14.4
Materials		housing: ABS; stainless steel (1.4404 / 316L)
Lens material		PMMA

Displays / operating elements

Display	switching status	1 x LED, yellow
	operation	1 x LED, green

Remarks

Pack quantity	1 pcs.
---------------	--------

Electrical connection

Cable: 2 m, PVC, black, \varnothing 2.9 mm; 2 x 0.08 mm²

diagrams and graphs

excess gain graph

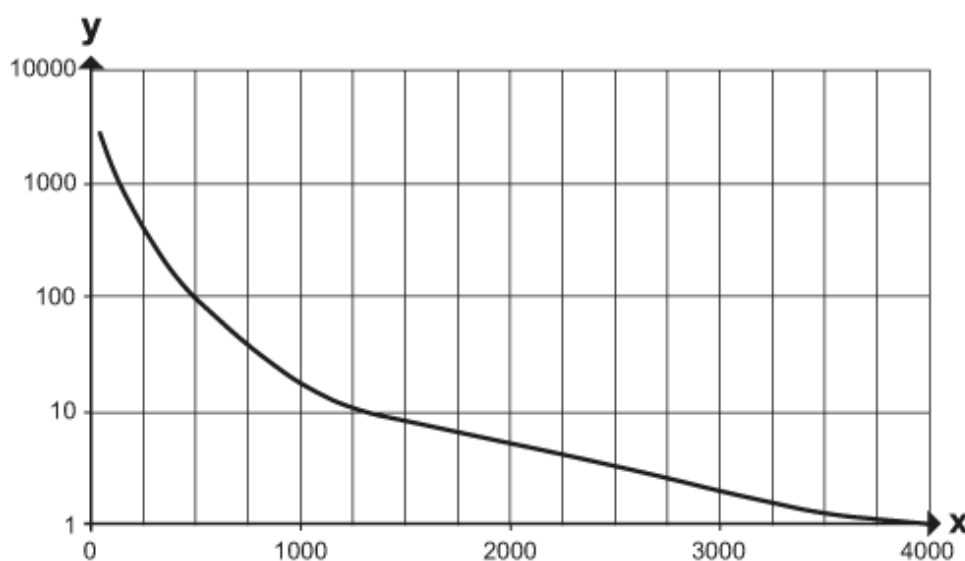

x: Abstand [mm]

y: Funktionsreservefaktor