

E30108

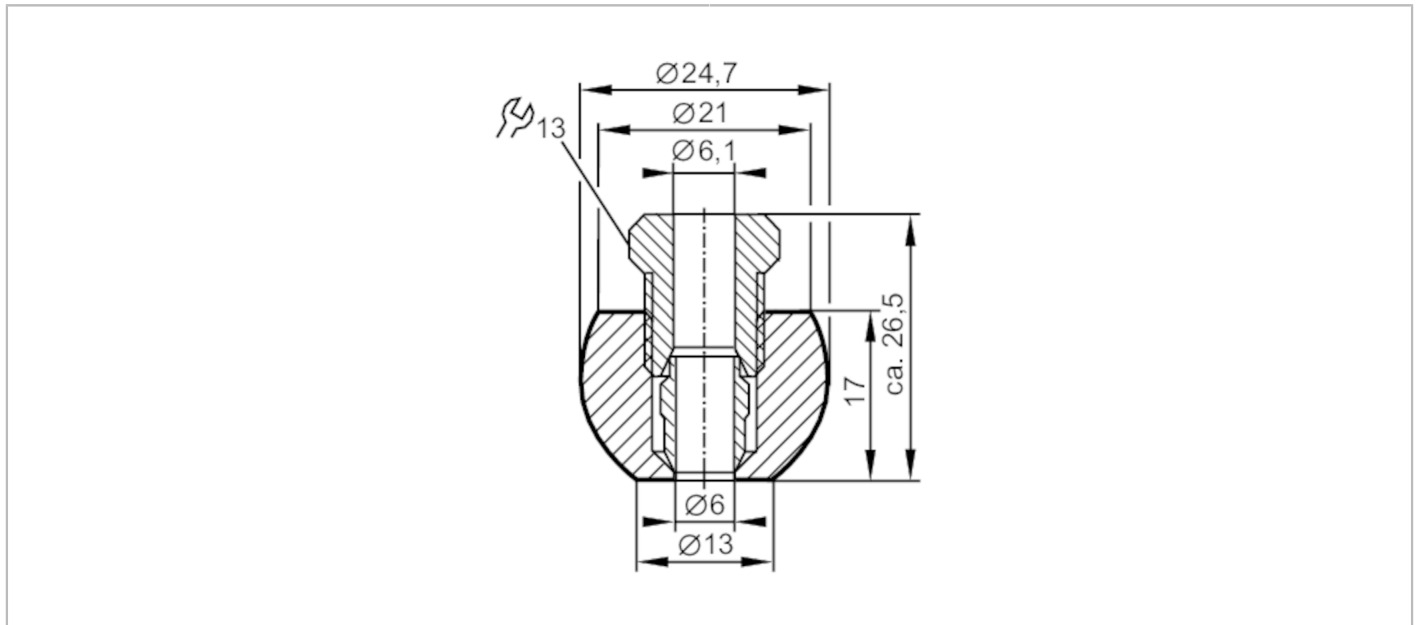

Welding adapter for process sensors

WELDING ADAPTER D6



Application	
Design	for temperature sensors Ø 6 mm
Installation	Clamp fitting
Pressure rating [bar]	160
Tests / approvals	
Pressure Equipment Directive	A possible classification to PED depends on the application and has to be carried out by the user / operator.
Pressure Equipment Directive EAC	The adapter is intended for use in devices, machines and installations that do not fall under the categories of the technical rule TR CU 032/2013.
Safety instructions	The compatibility between medium and product material has to be checked in all applications.
Mechanical data	
Weight [g]	63
Materials	stainless steel (1.4404 / 316L)
Sensor connection	Ø 6 mm
Process connection	welding adapter Ø 24,7 mm
Remarks	
Pack quantity	1 pcs.